

## INSTALLATION INSTRUCTIONS

DESCRIPTION: Clutch Cover Kit  
PART NUMBER: B7B-E54E0-V0  
MODEL: '19~ YZ250F



### **WARNING**

Please read and understand these instructions completely before installation to avoid possible injury to yourself, or damage to the accessory or vehicle.

**IMPORTANT:** YZ models are for closed-course competition only regardless of modification. YZ models do not meet federal or state emission standards for recreational off-road use.

### **NOTICE:**

Installation of this kit requires specialized tools, and training, as well as the Owner's Service Manual for the model. This installation should be performed by an authorized Yamaha dealer or a qualified mechanic.

### **WARRANTY INFORMATION:**

In the United States, see your Yamaha dealer for a copy of the Genuine Yamaha Parts and Accessories Limited Warranty Statement.

### **DEALER OR INSTALLER:**

These instructions contain important information for future reference and *must* be given to the customer.

## PARTS LIST:

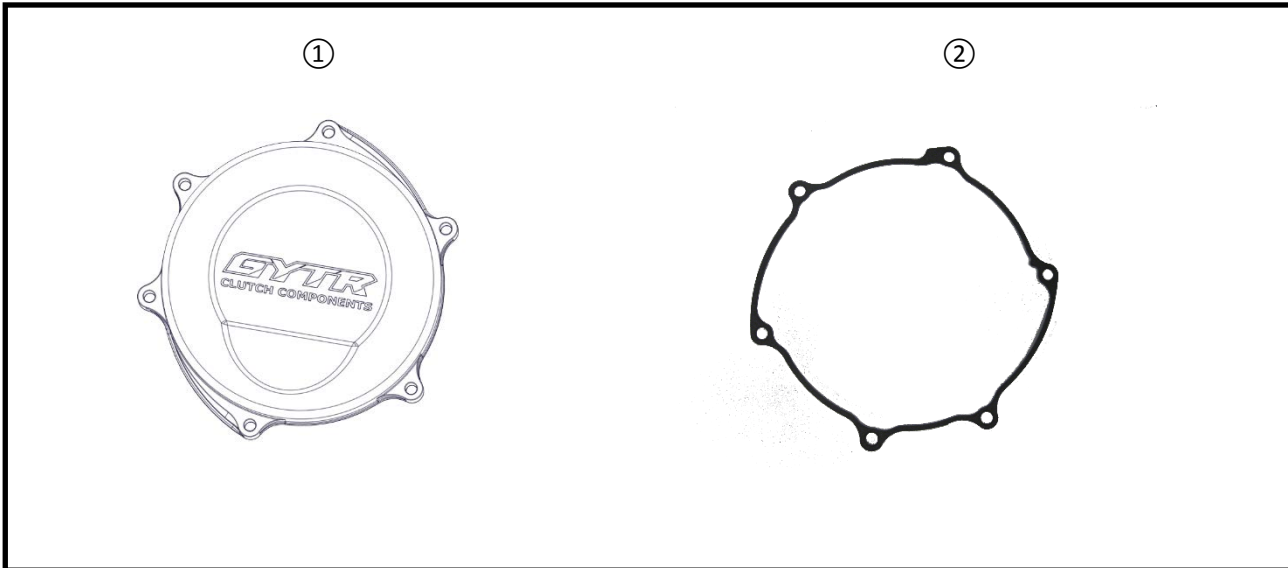

No.	Part Number	Description	Qty
--	B7B-E54E0-V0	Clutch Cover Kit	--
①	*	Clutch Cover	1
②	B7B-15453-00	Gasket, O-ring	1

\*Part supplied with kit only and not available separately.

Fig. 1

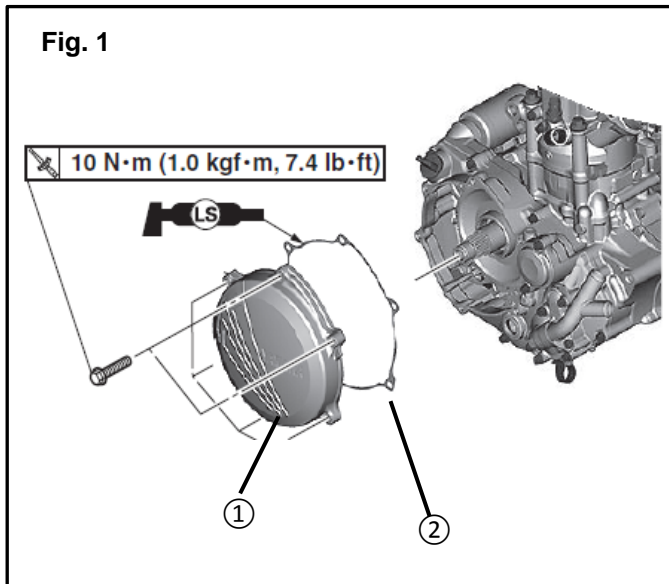

**PREPARATION:**

- Stand the motorcycle on a secure and level surface.
- Drain the oil from the engine.
- Alternately, lean the motorcycle on its left side, and ensure that any oil lost during installation is replaced.
- Clean all mounting surfaces before beginning installation.

**INSTALLATION:**

1. Remove the stock clutch cover referencing the Yamaha Owner's Service Manual. Retain all hardware as it will be reused.
2. Install the GYTR Clutch Cover (1) and gasket (2) using the stock hardware. (Fig. 1)
3. Torque clutch cover bolts to 10 Nm (1.0 m-kgf, 7.2 ft-lbf).

**TIP:** Tighten the clutch cover bolts in stages, using a crisscross pattern.

**MAINTENANCE:**

Periodically check all clutch cover bolts for tightness and re-torque as necessary.

**CARE AND CLEANING:**

Wash the exterior of the clutch cover with a mild soap and water solution and soft cloth.

**CUSTOMER SERVICE:**

For further information see your Yamaha dealer.

**ESTIMATED TIME TO INSTALL: 0.1 HRS.**